

SML

EXTRUSION LINES – ENGINEERED TO PERFORM ▶

▶ **Flexible
packaging,
laminated
composites &
aseptic
packaging**

Coating and laminating lines

www.sml.at

Turning complexity into productivity



The performance of an extrusion coating and laminating line can significantly affect a company's budget, with rejects being a major cost factor.

To optimise production and minimise waste, it's essential to select the optimal machine from the start.

SML advises their customers to choose the most appropriate coating and laminating line to suit their specific needs from a range of available options. From the extruder, the unwinder and laminator to the winders and the system control – our extrusion coating and laminating solutions are characterised by technical precision, reliability and easy operability. Most importantly, our human-centred approach, combined with decades of experience and a relentless drive for innovation, sets us apart in this complex market segment.

Advances in extrusion lamination

Thanks to sophisticated design and the precise interaction of high-performance components, extrusion lamination has reached new heights. Today, it's possible to create extremely thin laminates with exceptional breathability, as well as machines that can bond materials that were previously thought to be incompatible.

Manifold applications possible

SML provides customised all-in-one solutions for various applications and industries, including:

- ▶ Food packaging
- ▶ Hygiene and medical applications
- ▶ Construction
- ▶ Textile industry
- ▶ Automotive industry

Machine control and operation concept

For SML, extrusion lamination does not merely consist of glueing substrates together. In combination with SML's completely in-house developed machine control system SMILE, extrusion coating and laminating lines from SML empower manufacturers to shape the properties of end products to meet their needs.



Thanks to SMILE, components from sub-suppliers can be integrated in the lines, and precise settings for product changes can be managed easily with minimal time expenditure.

Data analysis

SML's data generation and analysis tool, bitWise, provides entirely new opportunities for data-driven decision making with a clear focus on the optimisation of production processes and the final product.



Content

| | | |
|---|------|--|
| FlexPack | ▶ 6 |  |
| Typical FlexPack coating & laminating products | ▶ 9 | |
| DoubleCoat process | ▶ 12 | |
| Triplex | ▶ 14 |  |
| Typical Triplex aseptic products | ▶ 17 | |
| Extra-wide extrusion coating & laminating lines | ▶ 20 |  |
| Component description | ▶ 22 | |
| Unwinder | ▶ 30 | |
| Winder | ▶ 34 | |
| SMILE control system | ▶ 38 | |
| bit.Wise data analytics | ▶ 40 | |
| Electrical retrofitting | ▶ 42 | |
| Service and support | ▶ 44 | |
| Technology centre | ▶ 45 | |
| Sustainability | ▶ 46 | |

IMPRINT Media owner, editor, publisher and editorial team: SML Maschinen GmbH, Gewerbestraße 32, A-4846 Redlham, phone: +43 7673 90999 0, e-mail: sml@sml.at; Produced by: VENDO Kommunikation + Druck GmbH, 4840 Vöcklabruck; Production location: at the printing company; Disclosure information in accordance with § 25 of the Austrian Media Act: www.sml.at; SML Maschinen GmbH reserves all property rights and copyrights to the media and the content thereof. We reserve the right to make changes and are not responsible for printing, typesetting, or technical errors. Source of images: © SML, Karin Hackl, Unipaco, Adobe Stock, ms.foto.group; The contents of this brochure are intended for information purposes only. These should not be perceived as legally binding. Edition: 04/2025



FlexPack

The path the web follows

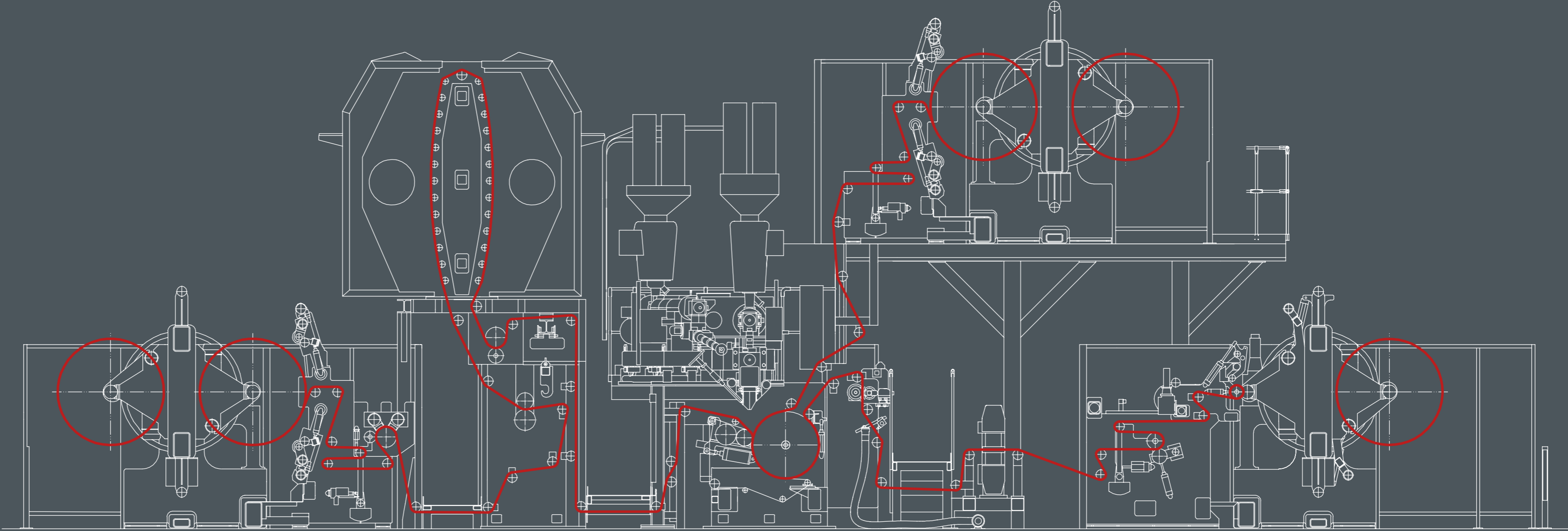

FlexPack

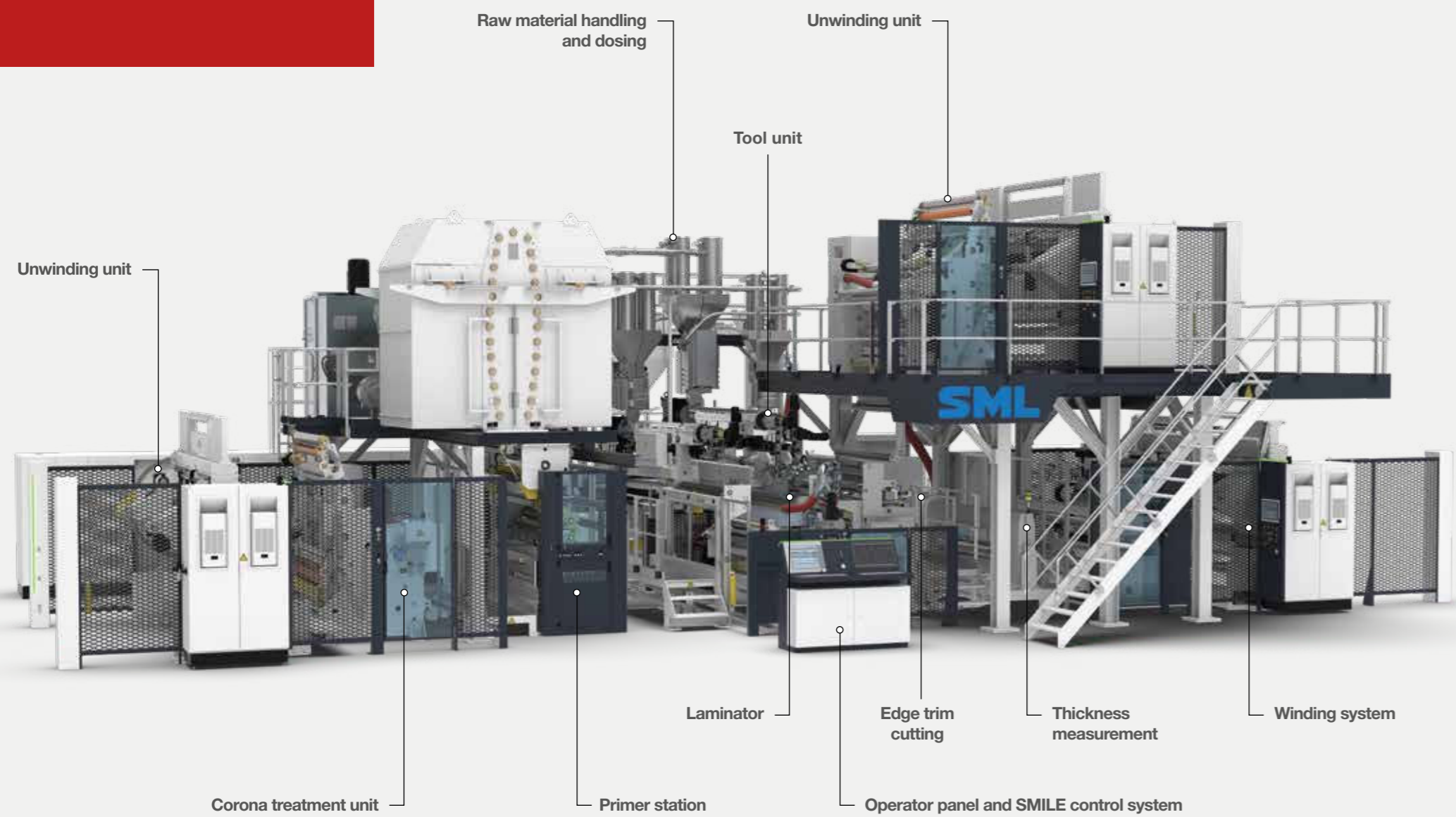

Typical FlexPack coating & laminating products





FlexPack

A highly modular line concept for coating and laminating

FlexPack stands out as a compact and modular laminating line for a **wide range of applications** – ranging from flexible packaging to textiles, and from construction to automotive products.

The demands on extrusion lines are evolving rapidly, driven by shifts in the market. At SML, we're committed to staying ahead of the curve.

Our FlexPack system is a prime example of this approach. It's designed to provide a reliable, efficient, and intuitive production process, resulting in exceptional product quality. The modular design also allows for flexibility and adaptability, enabling the addition of a second laminator to create complex laminate structures in a single step.

KEY FACTS AT A GLANCE

- ▶ Wide application area – from flexible packaging to applications in the technical sector
- ▶ Modular and compact line set-up
- ▶ Fair price/performance ratio

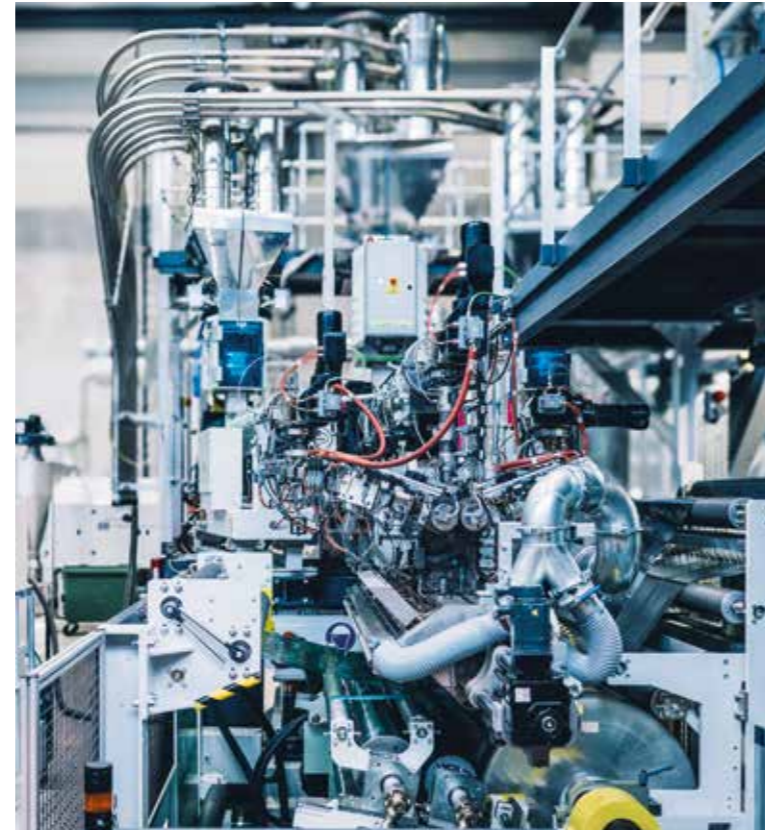

Flexible line configurations

Standard configuration compact

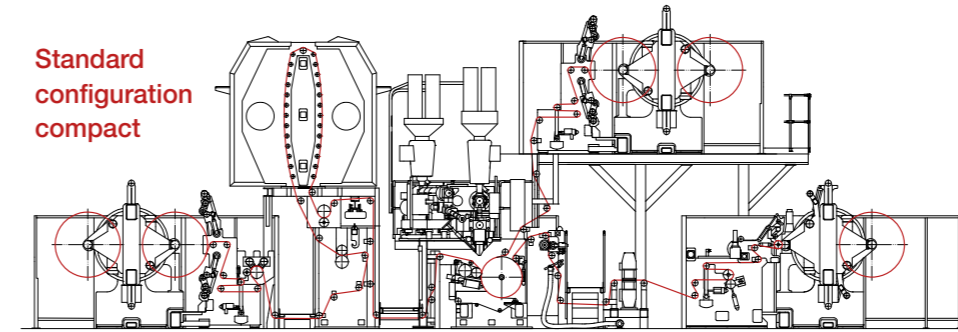

Standard configuration with ground-level platform

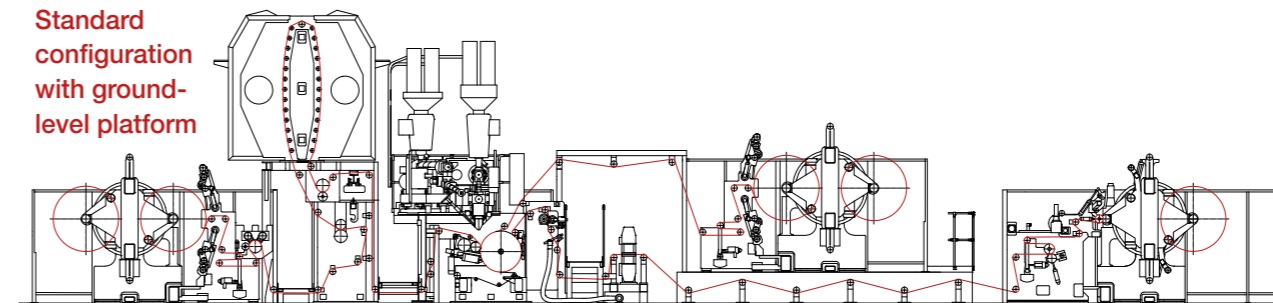

Tandem configuration

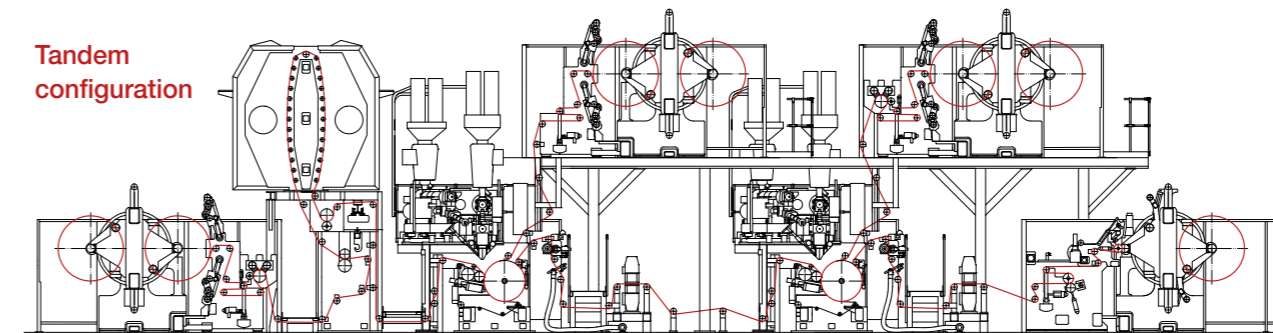

Processing various types of products

SML's FlexPack enables the production of a wide range of structures, incorporating various substrates, such as paper, film, aluminium foil, nonwovens and others. To support this versatility, our FlexPack lines are typically equipped with automatic turret unwinders and turret winders as standard.

Space-saving positioning of the unwinder

The unwinder is strategically positioned on the 1st floor to minimise required floor space. Although this requires reels to be lifted by crane, our customers' success stories demonstrate that the extra effort yields long-term benefits. The situation is different if there is sufficient floor space but not enough height, so that the unwinding device has to be positioned close to the floor. With this set-up, clients can easily monitor every line path and quickly detect any defects, ensuring optimal quality control.

Made to measure

At SML, we're always open to new ideas. Our FlexPack demonstration line at our Technology Centre allows us to test and validate special requests. The modular design of FlexPack offers a high degree of customisation, enabling us to meet even the most specific requirements. Plus, its flexibility makes it possible to retrofit the line if a different product is needed in the future.

More technical details:



DoubleCoat process

Patented sequential coating process



The smart way to produce more with less.

DoubleCoat is the key to **efficient production of extremely thin, breathable products** with exceptional properties at reduced material costs.

SML's patented DoubleCoat technology combines extrusion coating with lamination. This unique approach enables the joining of materials that were previously considered incompatible, such as applying a TPU or TPE coating layer to a nonwoven PP spunbond. The key to success lies in finding the perfect match between the substrate, adhesive, and extruded membrane.

Application areas are sanitary articles, functional clothing and products for the construction industry.

Impact on coating thickness

The coating thickness can be significantly reduced by applying hot-melt coating prior to extrusion coating. This results in an extremely low extrusion coating weight, and an attractive adhesion to the substrate is achieved. Furthermore, especially with TPU membranes, reducing the membrane thickness results in exceptionally good WVTR (water vapour transmission rate) values.

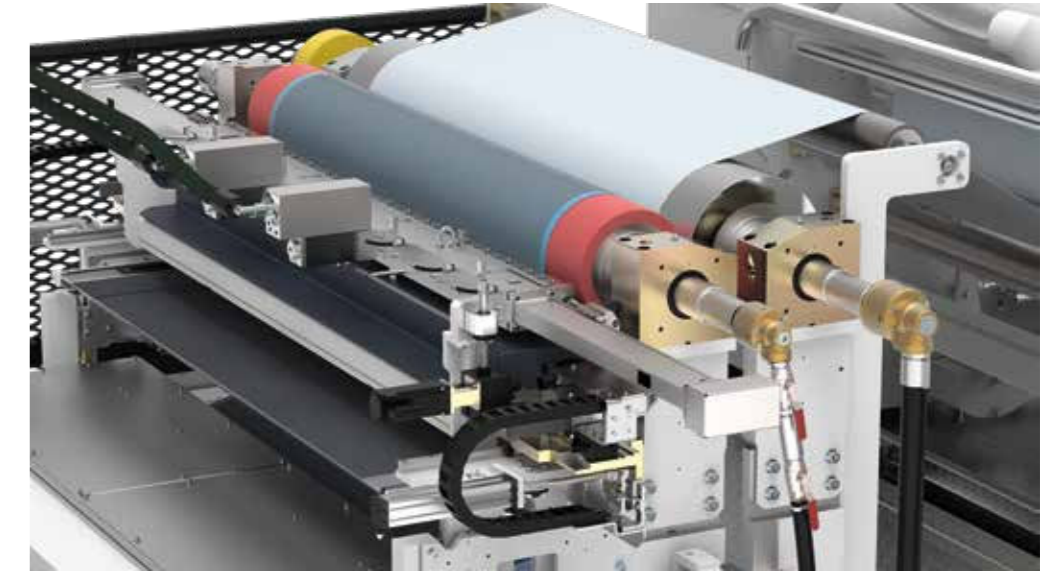

Hot-melt laminator

KEY FACTS AT A GLANCE

- ▶ Reduced coating layer thickness
- ▶ Material savings and hence lower costs
- ▶ Optimised adhesion with corresponding water column
- ▶ Improved breathability
- ▶ Enhanced mechanical properties

Triplex

The path the web follows

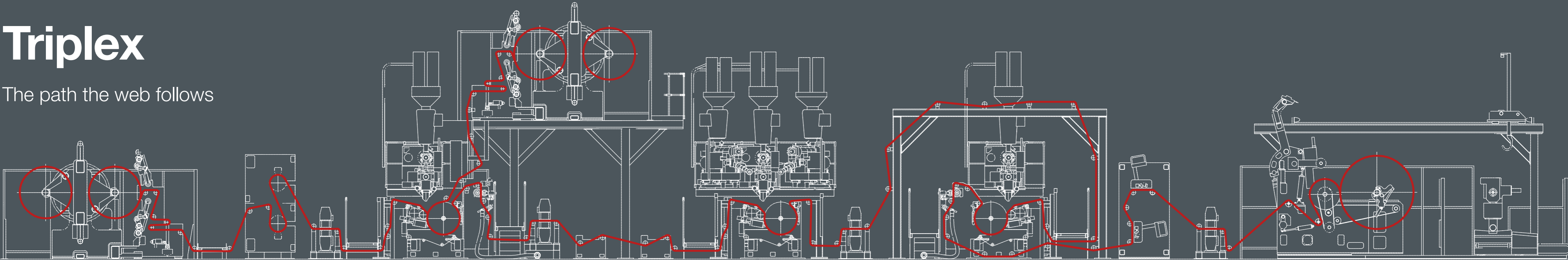

Triplex

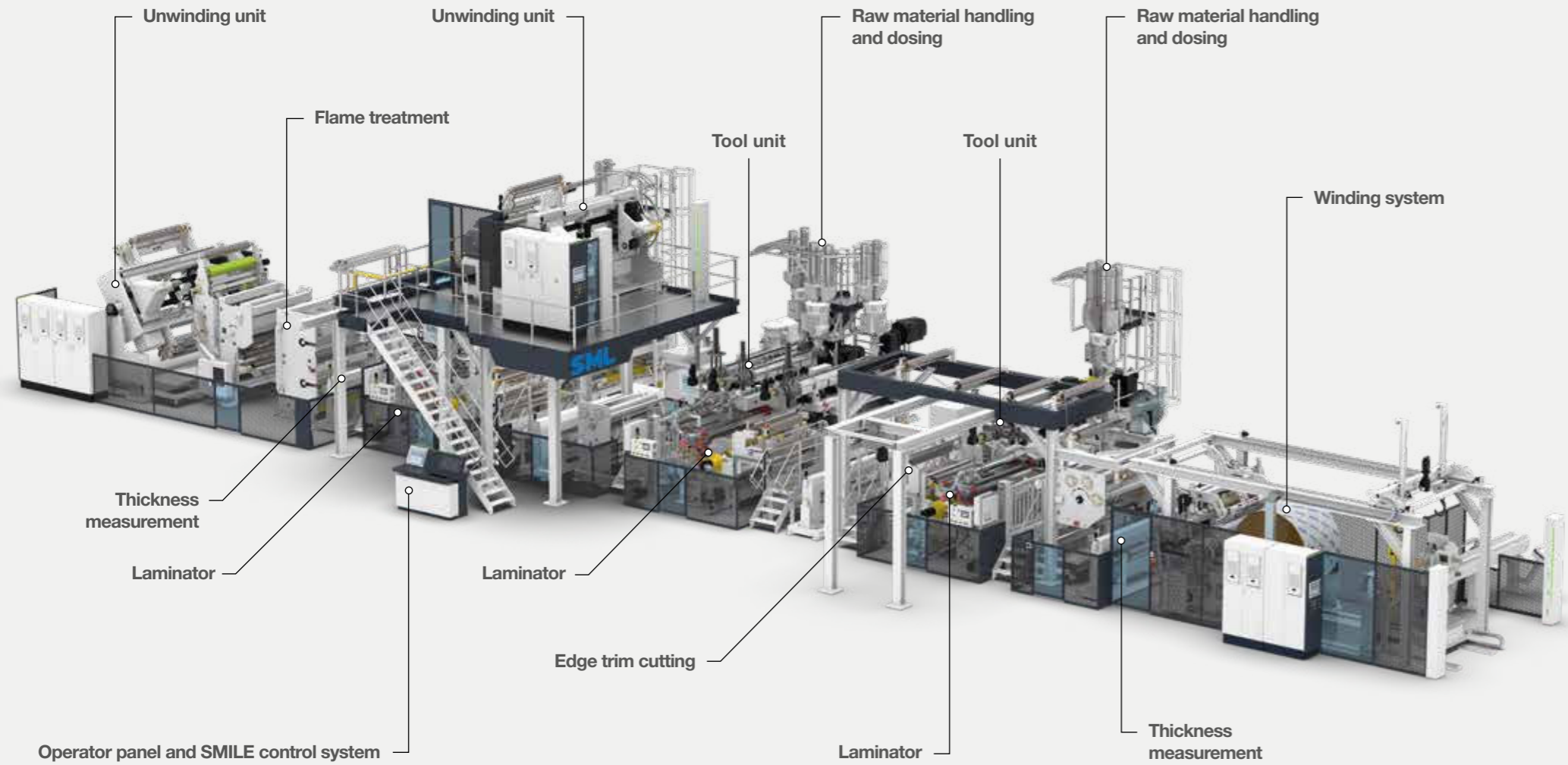

Typical Triplex aseptic products





Triplex

Precise interaction for the highest quality

Triplex is designed to produce **complex composite carton packaging** in one simple **and cost-effective process**. The application areas range from classical liquid beverage cartons to pouches.

Packaging beverages derived from natural sources, such as fruit juice, pose a particular challenge in system and process engineering. To meet the demands of this sector, machines must be durable, mechanical engineering must be robust, and machine control must be precise.

KEY FACTS AT A GLANCE

- ▶ Production of aseptic board laminates of high quality
- ▶ Optimised product change over – low waste
- ▶ Durable machine design and comfortable operation

More technical details:



Processing thin paper and paperboard

The Triplex extrusion laminating line offers a unique balance of sensitive tension control and robust design, making it ideal for processing materials like thin paper and rigid cardboard. Unlike other lines in its class, the Triplex line can handle both paper and rigid paperboard with equal high quality. Additionally, the line can be easily modified to run without aluminium or with alternative materials, providing flexibility and versatility.

Precisely controlled processes

The Triplex line features a sophisticated technical design, characterised by the seamless interaction between various machine units. This is made possible by SML's central machine control system, SMILE, which enables precise communication between different components, including PLCs, drives, and measuring cells. The system's sensitive tension control allows for rapid data exchange, occurring within microseconds.

Ready for heavy loads

The general line set-up of the Triplex extrusion laminating line makes changes of materials easy and fast. SML's fully automatic drum winder, W1800, is fitted with an automatic reel and shaft handling system. It supports the winding of heavy product rolls of up to 4 tons.



▶ Extra-wide extrusion coating & laminating line



Extra-wide extrusion coating & laminating line

For decades, SML has excelled in designing coating lines for extra-wide products. One key feature that sets these lines apart is their **robust machine frame**, specifically designed to withstand high web tensions and minimise vibrations.

Highly customised

Due to the unique specifications of extra-wide coating and laminating lines, these lines are fully customised. Each installation is distinct, with no two being alike. When it comes to automation, the SML team excels at implementing sophisticated interfaces, tailored to meet the specific needs of each project.

A long-term investment

Extra-wide coating and laminating lines have proven successful in various applications, including:

- Landfill liners
- Greenhouse films
- Sunshades
- Tarpaulins
- Reel wraps



KEY FACTS AT A GLANCE

- ▶ Massive machine frame to withstand high web tensions
- ▶ Well-proven for a wide range of different applications
- ▶ Tailor-made down to the last detail

Component description



Raw material handling

SML's gravimetric batch blenders and continuous gravimetric feeders guarantee material blending accuracy at the highest level. Up to six components per extruder can be processed, providing maximum flexibility.

Permanent output control

The continuous communication between the dosing and the extruder control system guarantees a constant and precise extruder output.

Exact repeatability of recipes

SML's complete dosing system, as well as all the material supply vacuum pumps, filters and valves are fully integrated in the SMILE machine control system. This enables the accurate reproducibility of recipes, so that changes in production can be implemented very quickly and easily. At the same time, waste is reduced to a minimum.

KEY FACTS AT A GLANCE

- ▶ Highest material blending accuracy
- ▶ Up to six different components per extruder
- ▶ SMILE control system for fast and efficient product changes



Extrusion unit

Extrusion unit

Extrusion systems developed by SML stand for technical precision, field-tested reliability and constant innovations. SML's long-time experience in screw design and its state-of-the-art in-house testing facilities enable the firm to create outstanding solutions for any polymer used for extrusion coating or lamination.

Choice of extruders

SML offers customer-specific extruder designs for all polymer types. As standard, a choice of screw diameters from 45 mm to 220 mm is available. An L/D ratio of 33 is the best solution to obtain a high melt temperature and excellent mixing results even at high speeds.

KEY FACTS AT A GLANCE

- ▶ Specific screw designs for all polymer types
- ▶ Superior melt quality

Optimised energy efficiency

The extruders are driven by energy-efficient, low-maintenance, water-cooled AC motors as standard. All extruder barrels are heated using SML's advanced heating system. A flap, which closes through gravity, prevents the hot air from escaping from the system and keeps the heat in the barrel.



Extruder 135

Melt filtration

Effective melt filtration is crucial for a stable production process and excellent melt quality. For the removal of impurities, such as unmelted or cross-linked particles, SML offers a variety of solutions. Manual filters can be used for standard virgin coating grades, while hydraulic, single-piston filters are used for materials requiring more frequent filter changes. For special applications, i.e. when a substantial share of recycled materials is processed, continuous filtration systems are used.

Melt pressure regulation valve

To enhance performance, an adjustable melt pressure valve can be installed downstream from the filter. This valve enables the adjustment of extruder back pressure, which has an impact on shear energy input. As a result, high and constant mixing performance is ensured over a large extruder output range. Additionally, the melt pressure valve helps to increase the melt temperature, leading to optimised adhesion properties.

KEY FACTS AT A GLANCE

- ▶ Different melt filtration systems
- ▶ Adjustable melt pressure valve (downstream of the filter)
- ▶ Motorised back pressure adjustment

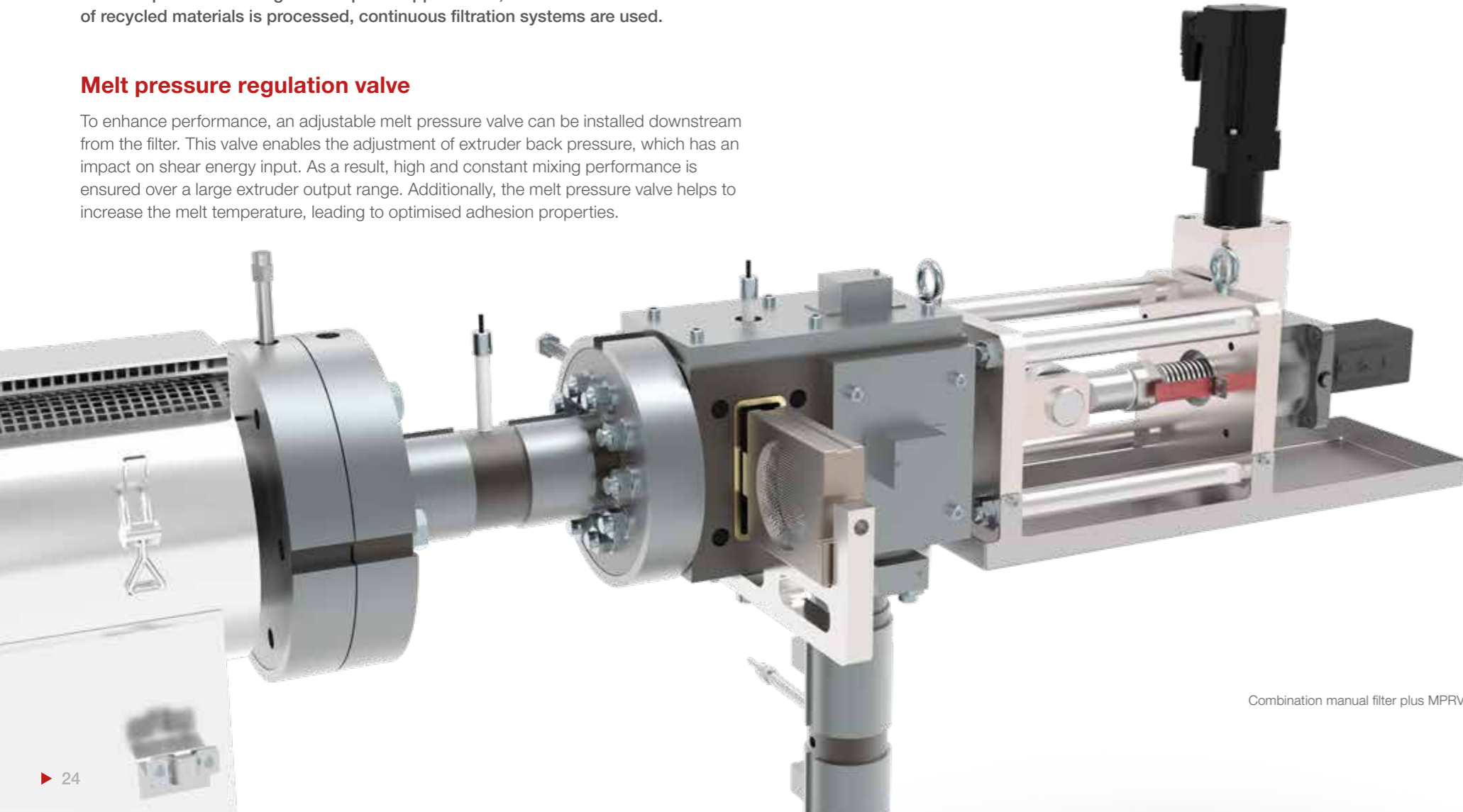

Combination manual filter plus MPRV

Feedblock and flat die

Multilayer structures require a high degree of flexibility with regard to feedblock adjustment. Therefore, SML utilises variable geometry feedblocks and inserts that can be profiled to optimise the thickness tolerances of the individual layers.

T-channel dies with internal and external deckling systems

SML offers different die designs in line with the respective application. Extrusion coating systems need to run in various product widths and so a die deckling is required. Flat dies with a coat hanger design have good distribution characteristics but can only be deckled with external decklings. Therefore, in recent years, the trend has been towards T-channel dies with internal and external decklings. The internal deckling consists of individually adjustable blades. This has the positive effect of influencing the edge bead and the neck-in of the melt curtain, which reduces the waste from overcoating.

Thickness profile adjustments can either be done manually or automatically – using die control with thermally heated bolts, or through fully automatic mechanical lip adjustment.

SML partners with trusted industry experts to source its feedblocks and flat dies. Depending on the manufacturer, dies are either chrome or nickel plated. In applications, where the extrudate is corrosive, stainless steel may be selected as a base material.

Fume suction as standard

SML provides fume suction in all of its extrusion coating lines. As an option, an additional electrostatic filtering system can be equipped with HEPA (high-efficiency particulate air) filters to clean the exhaust air, minimising adverse health effects and making overall production more environmentally friendly.

KEY FACTS AT A GLANCE

- ▶ High-end flat dies from respected partners
- ▶ Various types of deckling systems
- ▶ Manual or automatic die bolt control



Extruder carriage

The extruders of SML's coating and laminating lines are placed on the extruder carriage with the ability to oscillate. They can easily be moved to an offline parking position, i.e. to have comfortable access for die lip cleaning or for preparing the extruder at polymer changes. SML offers various extruder carriages with different specifications, depending on the width of the line and the number of extruders.

Recipe management for coating positions

The relative position between the point at which the melt contacts the substrate is a critical process parameter that varies by product. To accommodate this, the extruder carriage is designed to be adjustable in all three axes (x, y, and z). For enhanced repeatability, the system detects, displays, and stores the actual positions in recipes, ensuring precise control and consistency across different production runs.

Certain materials require a defined oxidation time. That's why SML lines feature a precise display of the time-in-air gap, automatically adjusted according to position and speed. This ensures operators always maintain full process control and achieve the highest product quality.



KEY FACTS AT A GLANCE

- ▶ Parking position with comfortable access for die lip cleaning
- ▶ Comfortable preparation of the extruder at polymer changes
- ▶ Oscillating extrusion units for an optimised reel profile



Laminating nip

Laminator

The laminator is the key component of an extrusion coating line, combining all different types of substrates to one single product structure. SML's laminators all have massive side frames that are directly mounted to the floor to ensure vibration-free production.

Precise roll arrangement

A pressing unit, consisting of a rubber roll and a steel supporting roll, is arranged on linear guides to precisely apply a defined pressure to the coating gap between the rubber roll and the chill roll. All rolls are equipped with quick-change couplings in order to complete roll changes for product surface changes in minimum time.

Minimised substrate waste

An endless PTFE tape allows overcoating to minimise substrate waste. An adjustable lift-off roller at the outlet of the unit ensures the consistent peel-off of the coated material from the chill roll.

Recipe management for exact repeatability

All parameters that have a direct impact on product properties are easily adjustable with SML's advanced machine control system, SMILE – i.e. the position of the die, the pressing force or the chill roll temperature. To ensure exact repeatability, all settings of the laminator can be stored in recipes.

KEY FACTS AT A GLANCE

- ▶ Massive side frames for vibration-free production
- ▶ Quick roll changes for fast product changes
- ▶ Waste reduction with PTFE tape attachment



Thickness measurement

SML supplies automatic gauging systems with ultrasonic, infrared, X-ray, or beta ray sensors. We offer single-frame solutions for total product measurements and multiple-frame systems for differential thickness measurements, ensuring synchronised measurements to maintain constant coating thickness despite substrate variations.

KEY FACTS AT A GLANCE

- ▶ Automatic gauging systems with ultrasonic, infrared, X-ray, or beta ray sensors
- ▶ Single-frame solutions with total product measurements
- ▶ Differential measurement system for a constant overall coating weight



Corona treatment station

A corona treatment unit modifies the surface tension or cleans the surface of a product, improving bonding strength and printability. It can be installed upstream or downstream of the coating and laminating process. In SML's coating lines, the unit is often integrated into the unwind side frames, reducing the overall line length. Ceramic or stainless steel electrodes are used, depending on the material's conductivity. The unit can be driven and equipped with a rubber pressing roll to control web tension, and is fully integrated into SML's SMILE control system for easy operation

KEY FACTS AT A GLANCE

- ▶ Corona treatment unit up- and downstream for specific adhesion and printing properties
- ▶ Fully integrated in the unwind side frames for a short web-path
- ▶ Easy and simple to operate with SML's machine control system, SMILE



Primer station

To enhance adhesion, a liquid primer coating can be applied to the pre-treated substrate surface using a roller coating system with a gravure roller and closed chamber doctor blade. This method offers high precision, increased production speed, and reduced spillage compared to conventional systems.

The liquid primer is then dried in a subsequent vertical drier, leaving a thin layer of solids on the surface that acts as an anchor for further processes. To minimise energy consumption, SML uses highly efficient drying equipment with adjustable air return and optimised flow speeds. Heating sources can be either electric, gas, oil or steam – depending on customer requirements.

KEY FACTS AT A GLANCE

- ▶ Gravure roll coating system with closed doctor chamber blade
- ▶ Highest precision, production speed and less spillage
- ▶ Energy-efficient drying process



Trim handling systems

In SML's extrusion coating lines, the edges of the product are trimmed immediately after the laminator. To minimise waste, precisely adjustable circular knives with driven counter knives or blade cuts are used. The cut trim is then sucked off and can be cut into small pieces to reduce storage and transportation volume, which is especially important for non-recyclable products.

KEY FACTS AT A GLANCE

- ▶ Edge trimming immediately after the laminator
- ▶ Precisely working circular knife system for optimal cutting
- ▶ Waste reduction through minimised edge trims

Precise and reliable unwinders are an essential part of any extrusion coating process. They guarantee substrate roll changes up to full production speed, preventing downtime and startup waste.

SML offers various types of unwinders for every requirement in production and for any type of substrate.

- ▶ Semi-automatic double-station unwinder with a manual splicing unit
- ▶ Zero-speed splicers with thermo-welding or butt splice with festoon
- ▶ Fully automatic turret unwinders, shafted or shaftless

Sensitive tension control

All SML turret unwinders are equipped with a lightweight dancer roll for sensitive tension control, while the substrate roll is centre-driven by an AC servo motor. During splicing, the new roll is automatically synchronised with the line speed. Splicing is carried out with a bump roll and a pneumatically operated chopping knife. By using a defined splice geometry and position detection, the splice length is minimised.

Modular set-up

All fully automatic turret unwinders are built in a modular design, which allows special features to be added to the basic machine. If needed, a second splicing unit for bi-directional unwinding, integrated edge guiding or an optional constant gap device for the smooth unwinding of thin and sensitive aluminium foil can be installed as an option.

The unwinders in SML's coating and laminating lines are equipped with a separate control cabinet and their own PLC system. The local control unit of the unwind is 100% synchronised with SMILE, the comprehensive overall control system of the line.



| Unwinder type | Double unwinder | UW 1500 WS/SL | UW1500 SL-H |
|-----------------------------|---------------------|------------------------------|------------------------------|
| Maximum mechanical speed | 150 m/min | 450 m/min | 600 m/min |
| Maximum substrate width | 5,200 mm | 2,400 mm | 4,500 mm |
| Maximum mechanical diameter | 1,500 mm | 1,270 mm | 1,600 mm |
| Core clamping | shafted / shaftless | shafted / shaftless | shaftless |
| Maximum roll weight | 4,500 kg | 2,000 kg | 4,000 kg |
| Unwinding direction | both | both | both |
| Roll handling | crane | crane/forklift/lifting table | crane/forklift/lifting table |

UW 1500 (WS/SL)

The turret unwinder UW 1500 is a **cost-efficient solution** for the fully automatic unwinding of a wide range of substrates. Splicing can be done up to full production speed.

At the UW 1500, an integrated edge guiding system ensures the correct alignment of the substrate. Therefore, no additional web guiding equipment is required.

Unwinding with shafts and shaftless

The UW 1500 is offered in two configurations: a version with winding shafts (UW 1500 WS) and a shaftless version (UW 1500 SL). At the winding shaft version (UW 1500 WS), shafts with a special circular adapter design are used for core fixation in combination with sliding safety chucks. In contrast, the shaftless version utilises mechanically actuated chucking heads, which are available in various sizes and can be easily interchanged for core clamping.

Roll handling is simple and straightforward at both versions, either with standard forklifts or hydraulic tables.

KEY FACTS AT A GLANCE

- ▶ Fully automatic unwinding with either winding shafts or shaftless
- ▶ Integrated edge-guiding system
- ▶ Recuperative AC drives for maximum energy efficiency



UW 1500 WS – shafted winding

UW 1500 SL-H

The turret unwinder UW 1500 SL-H is especially suitable **for heavy substrates** and large roll diameters. It handles widths up to 4,500 mm and maximum roll diameters of 1,600 mm.

Splicing can be done up to full production speed. Core clamping is done shaftless by mechanically actuated chucking heads of various sizes.

Maximum roll handling flexibility

Integrated lifting tables can be utilised for loading and unloading, which leads to maximum roll-handling flexibility in combination with minimum handling times. Each unwinding support is motorised in the transverse direction and can be linked to an edge-guiding system for the appropriate positioning of the substrate. As a result, no additional web-guiding equipment is necessary.

KEY FACTS AT A GLANCE

- ▶ Designed for heavy substrate rolls and widths up to 4,500 mm
- ▶ Shaftless core clamping with mechanically actuated chucking heads
- ▶ Integrated lifting tables for fast and comfortable roll handling



Winder

Winding systems

Winders engineered by SML stand for an unparalleled precision and for the best operational stability.

Over the years, SML has invested an enormous amount of effort into building its own peak performance winders for various applications. All these winders have a solid, vibration-dampening steel frame construction that is especially designed to resist the dynamic forces generated at high production speeds.

100% synchronised with SMILE

The winders in SML's coating and laminating lines are equipped with a separate control cabinet and their own PLC system. The local control unit of the winder is 100% synchronised with SMILE, the comprehensive overall control system of the line. Operator convenience is guaranteed by a self-explanatory and easy-to-operate user interface on a wide touch screen.



Choose the ideal winder for your application

| Winder type | 1500 WS/SL | W1800 | W2000 |
|-----------------------------|-------------|------------------|------------------|
| Maximum mechanical speed | 450 m/min | 600 m/min | 600 m/min |
| Maximum winding width | 2,400 mm | 4,800 mm | 2,900 mm |
| Inline slitting | No | Yes | Yes |
| Maximum mechanical diameter | 1,270 mm | 2,000 mm | 980 or 1,500 mm |
| Maximum roll weight | 2,000 kg | 4,000 kg | 2,500 kg |
| Winding direction | both | top wound inside | top wound inside |
| Winding tension | 50–750 N | 50–3,500 N | 30–300 N |
| Contact roll pressure | 100–1,800 N | 50–3,500 N | 50–500 N |
| Roll handling | manual | automatic | fully automatic |

Winder W1500 (WS/SL)

The turret winder W1500 allows reel changes at full production speeds and is available in two versions: W1500 WS with winding shafts and W1500 SL without.

Winding in gap or contact mode

A fixpoint unit at the winder inlet separates the web and winding tension. A lightweight dancer roll controls the winding tension, while the roll is centre driven by an AC servomotor. Winding can be done in gap or contact mode.

Winding in both directions

Cross-cutting systems with flying or chopping knives are available for smooth roll changes. In order to satisfy individual requirements, rolls can be wound in both directions by means of an optional second cutting unit. This design facilitates easy roll handling with standard forklifts.

Core fixation – core clamping

The version with winding shafts uses shafts with a special circular adapter in combination with sliding safety chucks for core fixation. In contrast, the shaftless version uses mechanically actuated chucking heads for core clamping, which can be easily exchanged.

KEY FACTS AT A GLANCE

- ▶ Cross-cutting systems with flying or chopping knives
- ▶ Fixpoint to separate the web and winding tension
- ▶ Dual direction winding

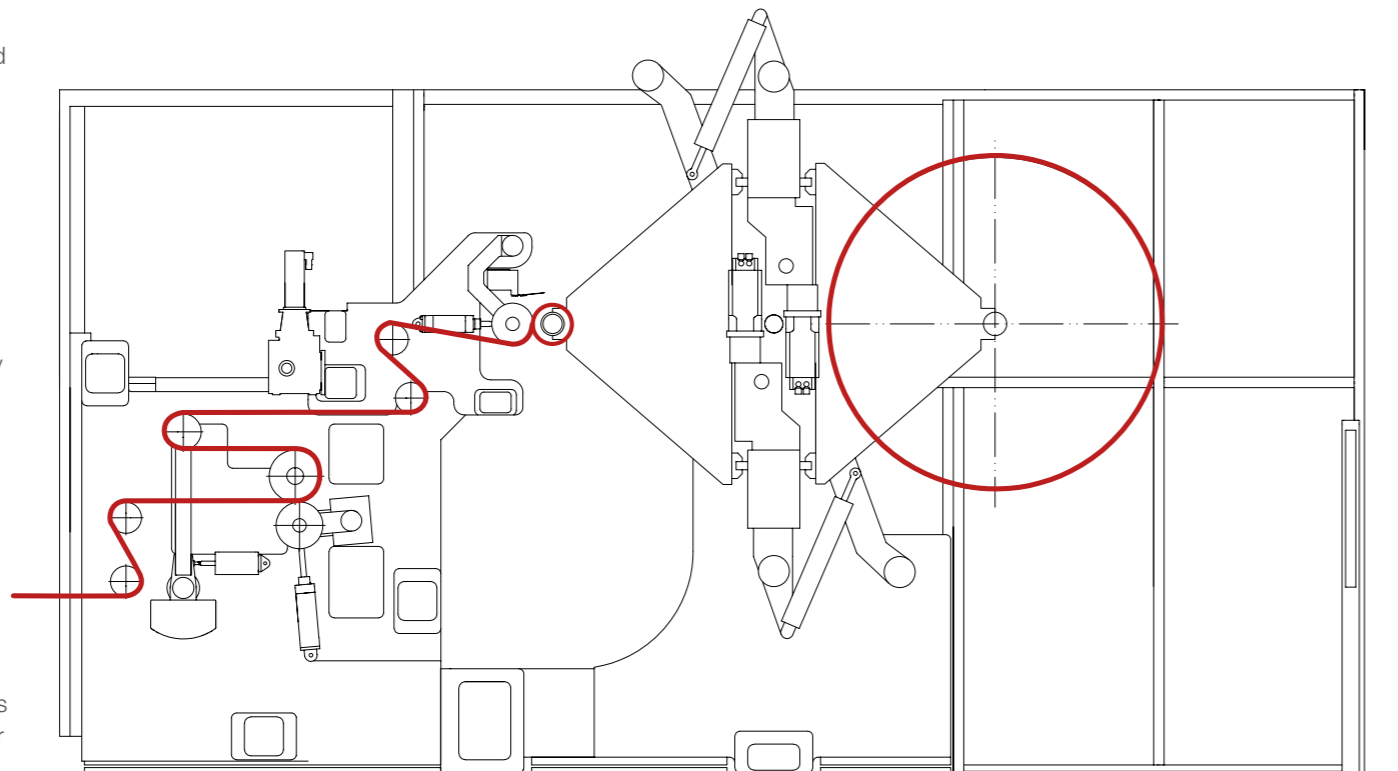

Winder W1800

The surface driven drum winder W1800 is for large widths of up to 4,800 mm and maximum roll diameters up to 2,000 mm.

In contrast to a turret winder, the winder W1800 is surface driven. The applied power of the contact winder motor does not have to be raised in accordance with increasing roll diameters. This permits a considerable reduction in both the motor power installed and the related energy consumption. For maximum flexibility, the drum winder can also be equipped with a centre drive for the shaft as an option.

Cross cutting with chopping or flying knives

Depending on the application, cross cutting is done by using a guillotine or a flying knife. Both versions are equipped with a satellite unit, which orbits the contact roll as a counter support on the winding drum for optimised cutting geometry.

Automatic shaft and reel-handling system

This winder is operated with winding shafts. An automatic shaft and reel-handling system is available as an option to ease the handling of heavy rolls and shafts.

Inline-slitting

The winder W1800 is optimal for inline slitting, since there is no turret rotation during change-over. The inline-slitting process can be carried out either with or without bleed trims.



KEY FACTS AT A GLANCE

- ▶ Designed for heavy product rolls and diameters up to 1,800 mm
- ▶ Surface driven, with minimal energy consumption
- ▶ Draw unit to separate the web and winding tension

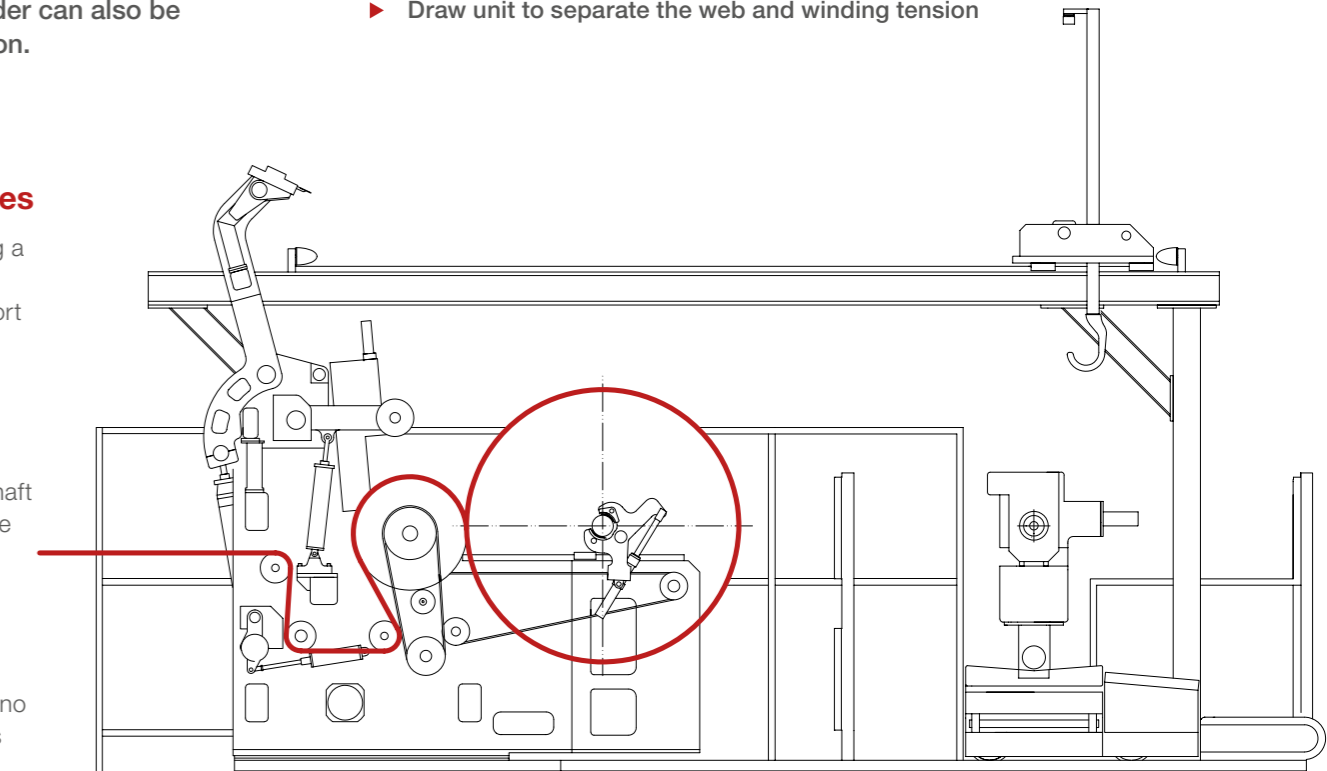

SMILE control system

The standard in machine control

SMILE is a comprehensive solution for machine control and operation. It simplifies machine handling and provides a clear overview and monitoring of the entire production process.

SMILE's user-friendly interface and customisable software ensure full integration of third-party systems and maximise line efficiency. Its advanced software structure offers superior data monitoring.

Developed in-house, SMILE combines with SML's extrusion lines for the precise, centralised control and synchronisation of all components. This technology enables innovative manufacturing, delivering unparalleled product quality, efficiency and output.

Intuitive machine control concept

SMILE is an integral part of SML's coherent and user-friendly overall line concept. The machine control and operation are highly intuitive and self-explanatory.

- ▶ Central control station for highest operating comfort and visualisation of all processes
- ▶ Reduced training requirements and error rates at operator level, less personnel required
- ▶ Remote control, remote update and remote service for minimised maintenance costs
- ▶ Multi-client / multi-user capability



E-container

Optimised production efficiency

One key purpose of SMILE is the enhancement of the Overall Equipment Effectiveness (OEE) through optimised production processes.

- ▶ Higher line speeds for higher output volumes
- ▶ Optimised use of raw materials, preventing production waste
- ▶ Greatest level of production reliability
- ▶ Minimised times for product change-overs – customisable assistant for product changes
- ▶ Customised machine functions such as innovative and state of the art controller systems lead to best machine performances

Systematised quality control

In close interaction with SML's data collection and analysis system bitWise, SMILE is an efficient tool to keep the output quality stable and to optimise output properties.

- ▶ Formula recipe system to copy production parameters
- ▶ Documentation and in-detail reporting of production processes
- ▶ Automatised alarm functions via e-mail or text message for quick debugging

Interconnectivity and third-party integration

Entirely web-based, SMILE has open interfaces that allow for straightforward data exchange with third-party machines and systems.

- ▶ Open to interconnect with systems like ERP, QA, cloud-based service or SML's data analysis tool bitWise
- ▶ Based on open standards like HTML5 and OPC-UA
- ▶ Complete end-to-end process control beyond SML extrusion lines

Integrated all-in-one concept

SMILE's all-in-one concept helps develop completely new types of solutions that turn even the most complex production processes into a single, user-friendly extrusion system. The temperature control and drive systems of all the SML extrusion lines are highly centralised. All line modules and motors are perfectly interconnected and synchronised with each other.

Central control station

SMILE's central control station allows the management of all production processes from wide touch screens attached to the line. A single SMILE control unit can control several extrusion lines. As SMILE is entirely web-based, all production and maintenance processes can be entirely remote controlled, i.e. from a PC or even a smartphone. The system is fully multi-client and multi-user capable: different types of users can log-in simultaneously.

Open for customisation

Developed in close consistency with the hardware components of SML's extrusion lines, SMILE is highly customisable. With 100% in-house development, it offers maximum flexibility to provide numerous possibilities and advantages to meet specific customer requirements.

In-house expertise for top performance

SML's comprehensive in-house expertise in automation and machine control enables us to offer a wide range of innovative functions. Our software solutions are developed entirely by SML engineers, and we have all the necessary knowledge to ensure the high flexibility of SMILE. As a result, our extrusion lines deliver top performance and offer both economic efficiency and environmental benefits.

KEY FACTS AT A GLANCE

- ▶ Central control station for all production processes
- ▶ Full interconnectivity – global OPC-UA, programmed on HTML5, open interface to other machines and systems
- ▶ Best production performance and reliability through long-term in-house know-how
- ▶ Remote access for operators and service teams – worldwide via internet, from any PC, laptop or most smartphones
- ▶ Multi-client / multi-user capability – simultaneous access for different type of users, simple assignment of permissions
- ▶ Highest comfortability – visualisation of all production processes on a big 24" screen
- ▶ Remote update for customisation and technical support on a global level

bitWise data analytics

Stop guessing, start knowing

With bitWise, SML's customers can analyse the entire process history of their SML extrusion line with a single click, rather than relying on current snapshots.

bitWise incorporates decades of experience in automation with the latest technologies in data analytics and provides a wide range of completely new opportunities for data-driven decisions.



In-depth view of all details

SML's extrusion lines are equipped with hundreds of data-generating sensors. bitWise records and visualises this data up to 10 times per second. In addition, each manufactured roll is provided with a QR code, which serves for identification. Putting everything together, manufacturers get an in-depth view of all the details involved in a production process – both in the present and in the past.

With bitWise, customers can look back at pressures within the system components and check whether there is a correlation with other measured values, such as temperature or laboratory results of a finished product.

KEY FACTS AT A GLANCE

- ▶ Highly customisable
- ▶ Easy integration
- ▶ Multi-machine capability
- ▶ Web-App

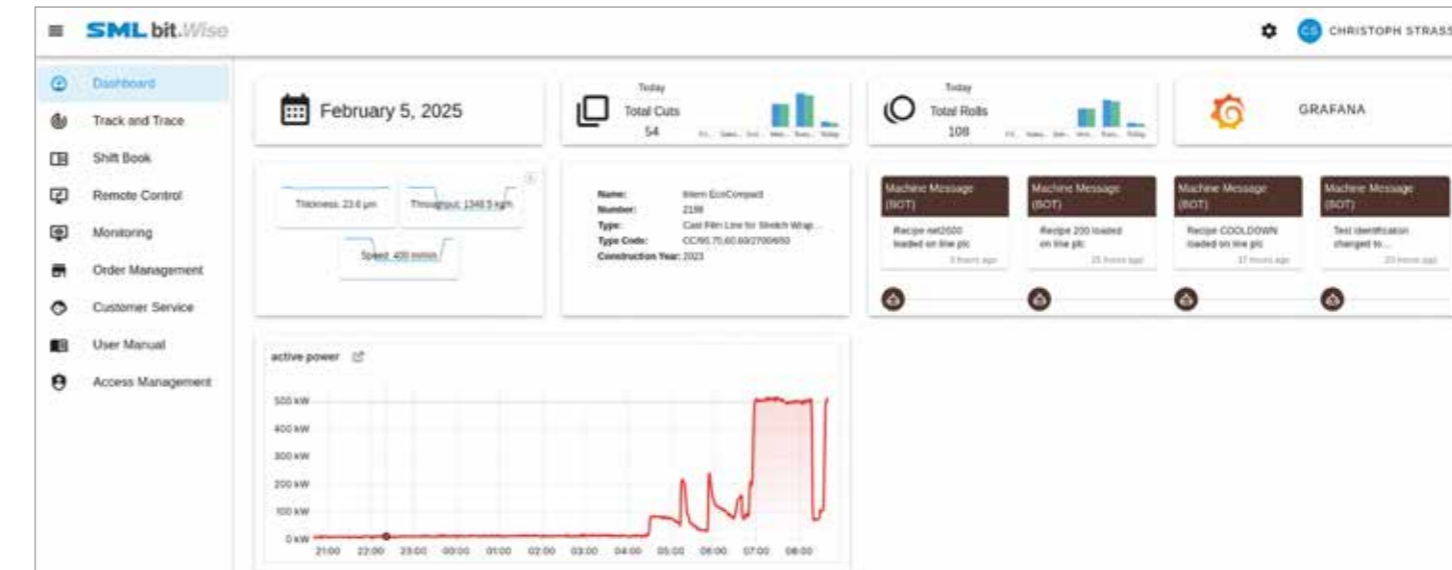

The bitWise dashboard provides an overview of the machine status; each user can configure it according to their needs.

Optimising quality

bitWise is a powerful tool for precisely optimising any aspect of the production process with a direct effect on product quality.

- ▶ Monitoring of all quality-related process parameters, allowing quick corrective action
- ▶ Comprehensive tracking and documenting of product quality
- ▶ Making quality reproducible

Minimising production costs

bitWise is the central tool for measuring and visualising all production-related costs. It forms a strong and reliable basis for continuous cost optimisation and contributes to a faster return on investment (ROI).

- ▶ Detailed monitoring and reporting of energy and raw material consumption
- ▶ In-depth optimising, tracking and reporting of Overall Equipment Effectiveness (OEE)
- ▶ Full end-to-end cost transparency through third-party integration

Maximising output

Recorded, aggregated and visualised data by bitWise help to raise overall line utilisation.

- ▶ Discovering hidden or unused output capacities
- ▶ Preventing downtime by detecting potential problems at an early stage
- ▶ Minimising maintenance times through optimised scheduling and structured access to documentation and service support

Open for vertical integration

At SML, we understand that extrusion lines represent a key part in a wider production chain. For end-to-end optimisation, bitWise therefore supports data exchange and vertical integration with third-party systems, such as Manufacturing Execution Systems (MES), Enterprise Resource Planning (ERP) or Quality Assurance (QA). Customers can simply retrieve the data from the system.

Choose your perfect interface

bitWise comes with a range of powerful functions that can be individually adapted. Customisable calendars, shift books and automated notifications provide a quick and user-friendly overview of all manual activities in production.

Always connected, even on the go

bitWise is a 100 % on-premises solution. This means that the data remains in-house on dedicated hardware; no cloud services are required. Nevertheless, customers can access bitWise in their company network via their VPN or a remote desktop solution.



Electrical retrofitting

For extended line productivity

Retrofitting pays off

Retrofitting can be a highly economical method for securing line availability and productivity for the years to come.

With its electrical retrofit programme, SML offers customers a personalised service to bring their lines up to the latest technical standard.

Securing future line availability

The electronics industry is fast-paced, with new developments constantly replacing existing systems. This can be a challenge for long-lasting extrusion lines.

Electrical retrofitting a solution to ensure line availability and production stability. SML guarantees the availability of the retrofitted components for 10 years after installation.

Extended service life – extended profitability

Electrical retrofitting from SML significantly extends the time in operation and overall productivity of an extrusion line, while total cost of ownership (TCO) is reduced. Compared to an investment in a new line, bringing an older extrusion line electrically up to date requires roughly 80% less capital, depending on the technical state of the line and the respective retrofitting measures. As with new extrusion lines, SML only installs first-class, state-of-the-art components for retrofits.



Operating panel (HMI)

KEY FACTS AT A GLANCE

- ▶ Securing future line availability and productivity at a moderate cost
- ▶ 10 years' guaranteed availability of spare parts
- ▶ Convenient and easy operation with state-of-the-art user interface
- ▶ A single-source solution from experienced SML technicians
- ▶ Greater sustainability compared to investment in a new line
- ▶ OPC-UA interface

Revised software set-up

Functional machine control and electronic systems guarantee the optimum interaction of different machine parts. The installation of state-of-the-art software means state-of-the-art functions for the better monitoring, analysis and maintenance of your machines. With the latest version of the modem installed, a remote service can be offered, and the best possible service support can be realised.

Up-to-date usability

In most cases, an electrical retrofit means changing the control system of an extrusion line. This also involves replacing the user interface with easy-to-operate 15" or 19" touch screens including RFID user handling.

Minimising downtime – one planned stoppage

The longer an extrusion line is in operation, the higher the risk of unplanned downtime. With a planned schedule for the retrofit, downtime can be calculated and the machine reliability can be improved again.



Frequency inverter

Which SML lines can be retrofitted?

Basically, all SML lines with a control system can be retrofitted. A retrofit makes sense for lines that lack one or more of these elements:

- ▶ B&R X20 control system
- ▶ ABB drives for extruders
- ▶ Lenze I550/ABB drives

The technical condition of an extrusion line is a key factor in determining whether retrofitting is feasible and, if so, which areas would benefit from it.

Customised solutions – examples

Based on a detailed inspection of the extrusion line, SML offers its customers highly customised retrofitting solutions:

- ▶ Exchange of PLC systems
- ▶ Replacing the PLC system and the drives
- ▶ Replacing all the electrical equipment
- ▶ All possible options in between

Benefits of a retrofit

State-of-the-art technical equipment

One planned stop with scheduled time

Guaranteed spare parts availability as for a new line

Higher line availability

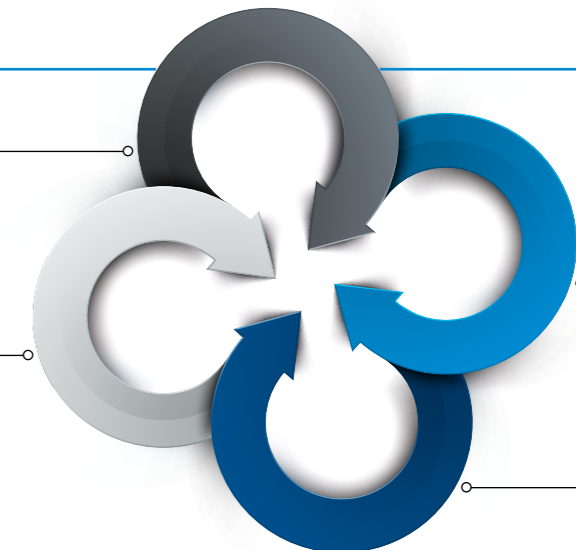

In addition to these more frequent solutions, the following upgrades have also been realised in response to customers' requests:

- ▶ Partial retrofit of specific units – e.g. only the winder and not the rest of the extrusion line, or vice versa
- ▶ Additional replacement of actuators (motors)
- ▶ Replacement of the PLC and HMI only, not of the IO nodes
- ▶ Replacement of the IO nodes only, not of the PLC
- ▶ Modification from DC motors to state-of-the-art AC motors

Experience and expertise for customer satisfaction

SML's electrical retrofit team consists of experienced engineers who have learned everything there is to know about SML's machinery over the course of their careers. In recent years, SML has carried out more than 30 retrofitting projects worldwide to the complete satisfaction of its customers.

Reliable assistance – around the globe, at all times

Outstanding end-to-end service support

Our highly-skilled technicians are at your service within 24 hours throughout Europe and within 48 hours in the rest of the world.



Always at your service

Our dedicated customer service team offers reliable assistance to ensure the continuous operation of any SML extrusion line at all times. Regardless of how long a system has been in operation, we assist every customer.

- ▶ Experienced SML service technicians
- ▶ Support via telephone, video call, chat, email and in person
- ▶ On-call service from 7 am to 10 pm CET
- ▶ Remote maintenance system
- ▶ Visual assistance via smart glasses as an option
- ▶ SML service technicians on call worldwide
- ▶ Quick on-site service

Service is our success

This slogan emphasises the importance of SML's outstanding service offering. In an industry where precision, reliability and continuous optimisation are essential, it is not only the quality of the machines themselves that matters, but also the service that accompanies them. We support our customers in all matters with a fast, efficient and solution-oriented approach. From maintenance and repairs to tailor-made solutions, excellent service ensures that machines remain efficient and companies can maintain their production efficiently. Ultimately, the success of a company is not only reflected in its technology, but also in the way it responds to the needs of its customers and supports them in the long term.

Up-to-date knowledge and experience

Our service team consists of technicians who know SML's extrusion lines inside out, having installed them themselves for many years. To keep their know-how up to date, all service employees continue to work regularly in everyday production. Their competence is reflected in the short response times to our customers' enquiries.

Immediate assistance

The remote maintenance system, which is available for every SML extrusion line, makes it easier to identify potential problems and provide a quick diagnosis. To find solutions, our service team works closely together with other departments at SML. This way, nearly all malfunctions can be solved remotely.

Time-saving solutions

A ticket system helps us manage enquiries and problems in a targeted and structured way, so that service requests can be processed faster and solutions found more quickly. This minimises downtime and maximises efficiency. Which in turn is reflected in customer satisfaction.

Visual assistance in real time

Through the use of smart glasses, our service team can provide real-time assistance worldwide. Whether our customers have technical problems, need help with product changes or maintenance work - they are guided step by step. This service is available for every extrusion line from SML.



Technology centre

Creating solutions together

SML helps you realise your ideas and test them sufficiently.

Our engineers and technicians relentlessly strive to craft the best solution for our customers. No matter the task or challenge you have in store for us, we will work with you at the Redham pilot plant to develop ideal solutions that go above and beyond the latest industry standards.

The production of customer samples and the joint development of new products and joint test series play a key role in SML's partnership with its customers. Joint R&D activities support mutual understanding, and through it, the anticipative fulfilment of customer wishes. And the findings generated together have a direct impact on the further development of new machinery and technology at SML.

Sustainability

A holistic approach to sustainability

“A holistic understanding of sustainability – from an ecological, social and business perspective – is firmly anchored in SML’s company culture. The concept of sustainability is integrated into all company processes and shapes our everyday actions. We implement the European Sustainability Reporting Standards (ESRS) consistently across the board as a clear commitment to transparency and responsibility.”

Karl Stöger CEO

In our sustainability targets, we focus on the following key areas:



With this clear focus, we contribute to forward-thinking development – economically successful, ecologically compatible and socially just.



Responsibility along the value chain

SML sees itself as an active part of the plastics value chain. We take responsibility within our own organisation as well as in upstream and downstream processes. Our Supplier Code of Conduct ensures that our social and ecological standards are also adhered to in upstream stages of the value chain.



► ENVIRONMENTAL

Reducing our climate impact – step by step

Today, all the electricity needs at our headquarters are met solely by green energy and our own photovoltaics system – this represents an important step towards reducing our direct emissions.

Other measures are targeting energy use in production, the mobility of staff and transportation. To reduce emissions even further, air freight and business trips are to be reduced by ten per cent by 2030 through measures including optimised planning and transport pooling. In addition, the company’s vehicle fleet is gradually being converted to electric-powered systems.

Focusing on systems efficiency

Machines from SML have always been highly efficient in terms of energy and resources. The continuous development of our technologies reduces the carbon footprint of plastics production and lowers emissions for our customers.

Circular economy through technology

Innovative systems and process technology are essential for a functioning circular economy. Our systems enable the processing of up to 100% post-consumer recycled material. SML takes a leading role in producing machines for manufacturing easily recyclable mono-material films.

Sustainability that reaches our customers

SML’s sustainability approach is reflected in the high quality of our systems, their retrofitting capability and our extensive service offering. Some SML systems have been in regular use for more than 30 years – a clear advantage for the environment and cost effectiveness.

► SOCIAL

Reliability and safety for people

SML is committed to a safe, stable and respectful working environment. Health and safety at work have the utmost priority – both in our own operations as well as in the development of machinery that is easy to use. Our sustainability targets include strengthening our operational training and development, increasing diversity and internationalisation of the workforce. This allows us to promote long-term development and social responsibility within the company.

► GOVERNANCE

Sustainability: our path to the future

Sustainability is an integral component of SML’s company strategy and values. We have already achieved some of our sustainability targets – others can still be improved upon.

By including sustainability in our company policies, we are able to track and measure our progress on an ongoing basis. Environmentally, our aim is to be climate-neutral by 2050. As regards our social impact, we aim to be seen as a model company for our employees.



► For more information
follow the link



Engineered to perform.

SML – the leading manufacturer of high-end extrusion lines

- Cast film lines
- Sheet lines
- Coating and laminating lines
- Spinning lines
- Winding technology

SML – Headquarters / Production site

Gewerbepark Ost 32
4846 Redlham
Austria
Phone: +43 7673 90999
E-mail: sml@sml.at
www.sml.at

Locations / Service units

Malaysia · China · USA · Brazil

